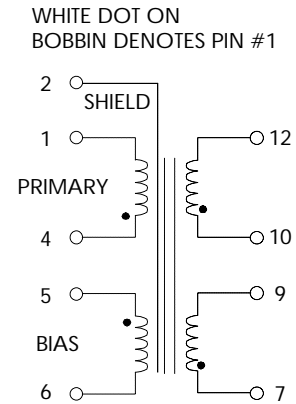

**TABLE 1: ELECTRICAL SPECIFICATIONS AT 25 °C**  
 SWITCHING TRANSFORMER DESIGNED FOR USE WITH POWER INTEGRATIONS  
 TOP247Y . REFER TO APPLICATION CIRCUITS OF FIGURE 3.

PARAMETER	SPEC LIMITS			UNITS
	MIN.	TYP.	MAX.	
PRIMARY INDUCTANCE (4-1) VOLTAGE = 0.250Vrms FREQUENCY = 100 KHZ	300	320	350	μHY
TURN RATIO'S: SEC (7-9) : PRIMARY (4-1) SEC (10-12) : PRIMARY (4-1) BIAS (5-6) : PRIMARY (4-1)	-----	1:8.25 1:8.25 1:6.6	-----	± 3% ± 3% ± 3%
PRI LEAKAGE IND. (SEC SHORTED) VOLTAGE = 0.250Vrms FREQUENCY = 100 KHZ	-----	-----	16.0	μHY
HIPOT: PRIMARY TO SECONDARY BIAS TO SECONDARY	3000 3000	----- -----	----- -----	Vrms Vrms
FIGURE 3A CIRCUIT PARAMETERS: (1) AC LINE VOLTAGE 60 Hz OUTPUT VOLTAGE OUTPUT CURRENT CONTINUOUS OUTPUT CURRENT PEAK LINE REGULATION (85 TO 265Vac) LOAD REGULATION 10-100% RIPPLE	85 ----- 0.0 ----- ----- ----- ----- -----	----- 25.0 ----- ----- 0.20 ----- 50.0	265 ----- 2.5 3.0 ----- ----- -----	Vac Vdc Amps Amps ±% ±% ±mV

**FIGURE 1: SCHEMATIC DIAGRAM**



**NOTE1:**

- A) ALL MATERIALS MEET "UL", "CSA" & "IEC" REQUIREMENTS
- B) TRIPLE BASIC INSULATED SECONDARY.
- C) DESIGNED TO MEET >6.2mm CREEPAGE REQUIREMENTS.
- D) VARNISH FINISHED ASSEMBLY.

**FIGURE 2: PHYSICAL DIMENSIONS mm (INCHES)**

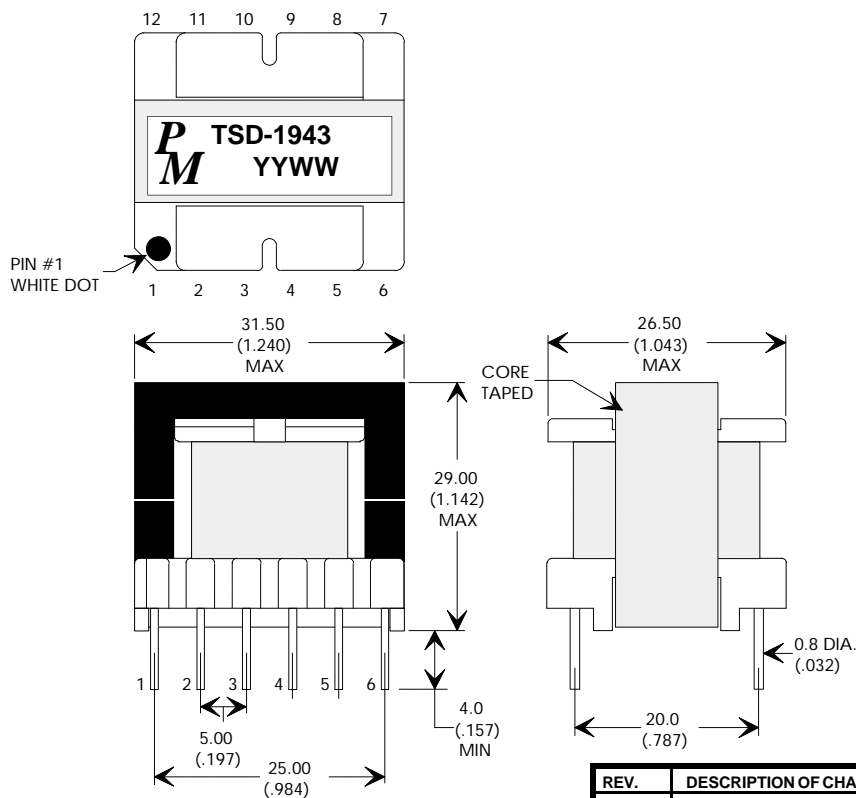

REV.	DESCRIPTION OF CHANGES	BY
12/18/03	ORIGINAL RELEASE	PP
01/15/04	CORRECT ON SCHEMATICS ON SEC'S	PP



UNLESS OTHERWISE SPECIFIED  
 DIMENSIONS ARE IN MM  
 DIMENSIONAL TOLERANCES ARE:  
 DECIMALS ANGLES  
 .X ± .25 ±0° 30'  
 .XX ± .15  
 DO NOT SCALE DRAWING

TRANSFORMER CONTROL DRAWING	
PREMIER P/N: TSD-1943	REVISION: 01/15/04
DRAWN BY: PETER PHAM	REF: TOP247Y
SCALE: NONE	SHEET: 1 OF 4

## APPLICATION NOTES

Premier Magnetics' TSD-1943 Switch Mode Transformer was designed for use with Power Integrations, Inc. TOP247Y off-line PWM switching regulator in the Flyback Buck-Boost circuit configuration. This conversion topology can provide isolated multiple outputs with efficiencies up to 82%. Premier's TSD-1943 transformer has been optimized to provide maximum power.

The PWR-TOPXXX series from Power Integrations, Inc. are self contained 132KHz three terminal voltage controlled PWM switching regulators. This series contains all necessary functions for an off-line switched mode control DC power source. These switching regulators provide a very simple solution to off-line designs. The inductors and transformer used with the PWR-TOPXXX are critical to the performance of the circuit. They define the overall efficiency, output power and overall physical size.

Below is a universal input high precision 62.5 watt application circuit utilizing Power Integrations TOP247Y switching regulator in the flyback buck-boost configuration. The component values listed are intended for reference purposes only. Properly sized heat sinks for the TOP2XX & D3 as well as proper thermal management of the clamp network are critical requirements for efficient and reliable operation.

**FIGURE 3: TYPICAL APPLICATION CIRCUIT**

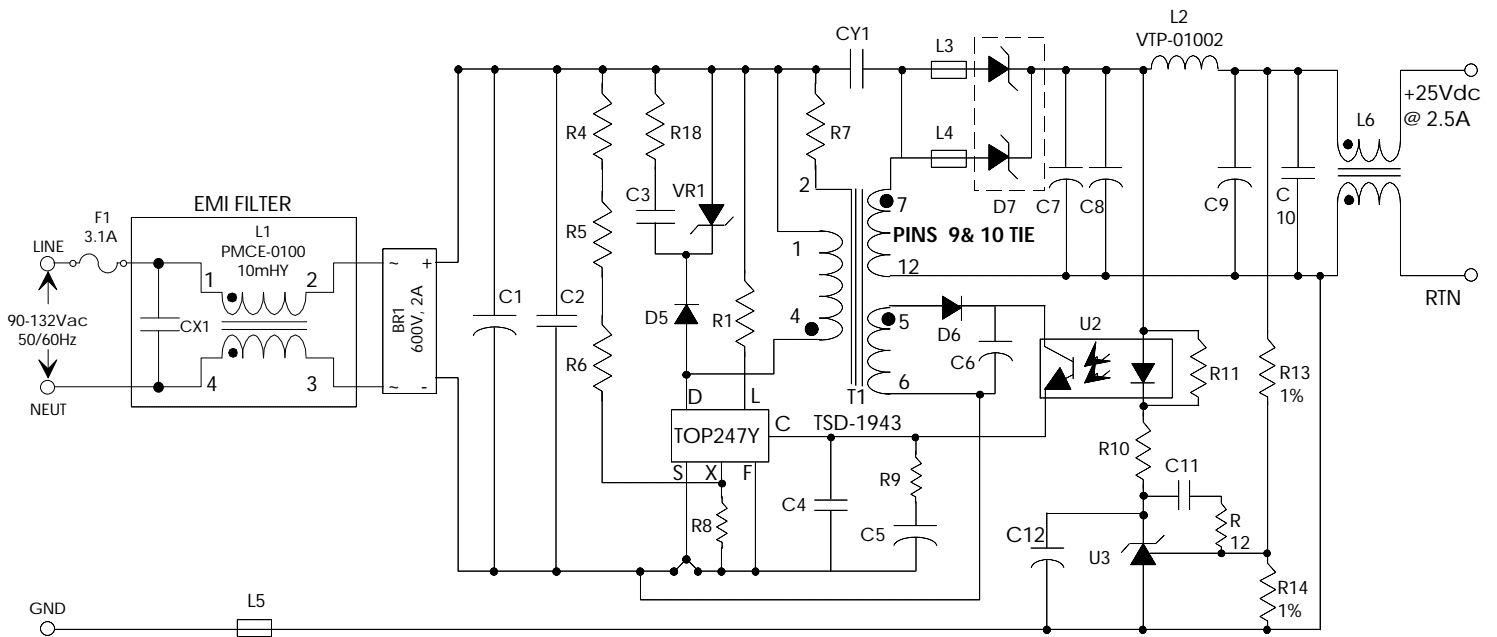

PREMIER MAGNETICS PART NUMBERS:  
(REQUEST DATA SHEETS BY PART#)

T1 = TSD-1943 MAIN SWITCHING TRANSFORMER

L1 = PMCE-0100 10mHy EMI/RFI CMC

L2 = VTP-01002 8uHy@4.0A(10uHy@2.0A) INDUCTOR

### OTHER PART LIST

TOP247Y

R1 = 2MOhm, .5W; R4, R5, R6 = 2.7M Ohm; R7 = 220Ohm

R8 = 15Oh; R9= 6.8Ohm; R10 = 470Ohm; R11 = 1KOhm

R12 = 4.7KOhm; R13 = 38.3KOhm; R14 = 10KOhm

C1 = 100uF, 400V; C2 = 20nF, 1KV; C3=34.7nF, 1KV; C4 = 100nF; C5 = 47uF, 10V

C6 = 1uF, 50V; C7 = C8 = 680uF, 50V; C9 = 220uF, 35V; C10 = 100nF

C11 = 47nF; C12 = 22uF, 25V

VR1 = P6KE200

D5 = UF4005, D6 = 1N4148, D7 = MBR20100

U2 = LTV817A, U3 = TL431

L3, L4, L5, L6 = BEAD (L3, L4, L6 = 1T, L5 = 3T)

BEADS L3 & L4 ARE PLACE ON D7 ANODE LEADS



UNLESS OTHERWISE SPECIFIED  
DIMENSIONS ARE IN MM  
DIMENSIONAL TOLERANCES ARE:  
DECIMALS ANGLES  
.X ± .25 ±0° 30'  
.XX ± .15  
DO NOT SCALE DRAWING

### TRANSFORMER CONTROL DRAWING

PREMIER P/N: TSD-1943	REVISION: 01/15/04
DRAWN BY: PETER PHAM	REF: TOP247Y
SCALE: NONE	SHEET: 2 OF 4